

# GX 12/29 BASIC PLUS AGM FREE LIFT

THE COMPACT STACKER WITH LONG AUTONOMY



This compact, powerful and robust stacker is the ideal solution for working in confined spaces.

The reduced width (800 mm), the lateral driving system and the wide mast positioning allow great manoeuvrability, stability and visibility.

Built-in battery charger with integrated cable and plug make it a plug and play unit!

## FREELIFT

This stacker is available with a total Free Lift configuration, enabling to rise the forks up to 1492 mm from the ground level, without increasing the minimum machine height (1965 mm).

This makes it possible to use the stacker even in workplaces characterized by reduced heights.

## MANOEUVRABILITY

The overall width has the same size than the EuroPallet (800mm) allow the unit to work in narrow spaces and corridors, increase maneuverability and reducing the turning radius.

The combination of the lateral drive, the wide mast and the low carter offer outstanding visibility.

*Plus AGM FreeLift*  
**GX 12**



## TILLER BASIC

Fully integrated ergonomic tiller system including finger tip throttle and fork controls, safety pushbutton, horn, and turtle button is the standard equipment of the GX BASIC



## TURTLE MODE SWITCH

Offered as standard, this function enables operating the truck in confined spaces: it allows the unit to travel with the tiller in upright position.

This function is activated by pressing the turtle button on the tiller and rotating the drive control throttle. The truck travels at limited speed.

Release the button to disable this function.



## COVER

Strong ABS carter/cover with storage compartments on top, easily removable to speed up maintenance operations. The bottom access opening allows an immediate disassembly of motor wheel, portal and tiller without lifting the machine. Schuko plug with spiral cable for an easy battery charging.



## BATTERY PACK AGM

A separate compartment is the housing of AGM deep cycle batteries. Such batteries are powerful (110Ah), allow 3 hours endurance and don't need maintenance. GEL batteries available on demand.



## Descriere

1.1 Producător			PR INDUSTRIAL
1.3 Comandă			ELECTRICĂ
1.4 Poziție operare			Pedestru
1.5 Capacitate maximă	Q	Kg	1200
1.6 Distanța la centrul de aplicare al sarcinii	c	mm	600
1.8 Sarcina de la osie la capătul furcilor	x	mm	780
1.9 Ampatament	y	mm	1234

## Greutăți

2.1 Greutate de operare (acumulator inclus)		Kg	615
2.2 Sarcină osie, încărcare pe spate		Kg	1187
2.2 Sarcină osie, încărcare pe față		Kg	628
2.3 Sarcină osie, liber față		Kg	453
2.3 Sarcină osie, liber spate		Kg	162

## Cauciucuri/Șasiuri

3.1 Cauciucuri: roți direcție			CAUCIUC
3.1 Cauciucuri: roți stabilizatoare - Față			POLY.C.
3.1 Cauciucuri: transportoare cu role			POLY.C.
3.2 Mărime cauciuc: roți direcție - Lățime		mm	76
3.2 Mărime cauciuc: roți direcție - Diametru		mm	250
3.3 Mărime cauciuc: transportoare cu role - Diametru		mm	82
3.3 Mărime cauciuc: transportoare cu role - Lățime		mm	70
3.4 Mărime cauciuc: roți stabilizatoare față - Diametru		mm	100
3.4 Mărime cauciuc: roți stabilizatoare față - Lățime		mm	38
3.5 Dimensiune cauciuc: roti spate		nr	2
3.5 Dimensiune cauciuc: roti fata		nr	1x+1
3.6 Ecartament, față	b10	mm	565
3.7 Ecartament, spate	b11	mm	410

## Dimensiuni

4.2 Înălțime, catarg coborât	h1 mm	1965
4.3 Înălțime de lucru fără încărcătură	h2 mm	1402
4.4 Înălțime stivuitor	h3 mm	2810
4.5 Înălțime, catarg ridicat	h4 mm	3372
4.9 Înălțime manetă în poziția de deplasare, max	h14 mm	1330
4.9 Height of tiller in drive position min	h14 mm	960
4.15 Înălțime, coborât	h13 mm	90
4.19 Lungime globală	l1 mm	1760
4.20 Distanța până la suprafața frontală a furcilor	l2 mm	609
4.21 Lățime globală	b1 mm	800
4.22 Dimensiuni furcă - grosime	s mm	70
4.22 Dimensiuni furcă - Lățime	e mm	150
4.22 Dimensiuni furcă - Lungime	l mm	1150
4.24 Lățime furcă transpalet	b3 mm	650
4.25 Distanța între furci	b5 mm	560
4.32 Gardă la sol și mijloc ampatament	m2 mm	20
4.34 Lățime culoar	Ast mm	2210
4.35 Rază de virare	Wa mm	1430

## Performante

5.1 Viteză de deplasare cu incarcare	Km/h	4.7
5.1 Viteză de deplasare fără incarcare	Km/h	5.2
5.10 Frână de serviciu	REVERSE CURRENT BRAKING	

## Motoare electrice

6.6 Consum de energie în ciclu VDI	kWh/h	0.9
8.4 Nivel sonor la nivelul urechii șoferului	dB(A)	62

## Elevare reziduală capacitate

Înălțimea de elevare (H3) 2500 mm	Kg	1200
Înălțimea de elevare (H3) 2900 mm	Kg	800

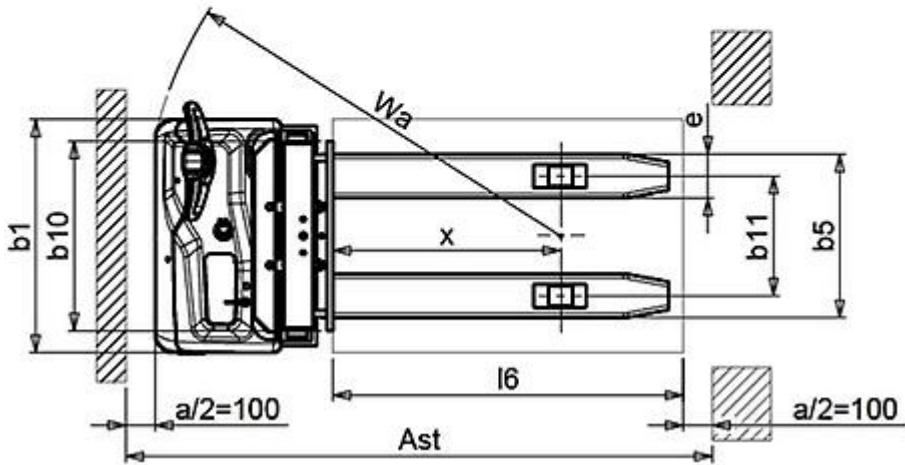
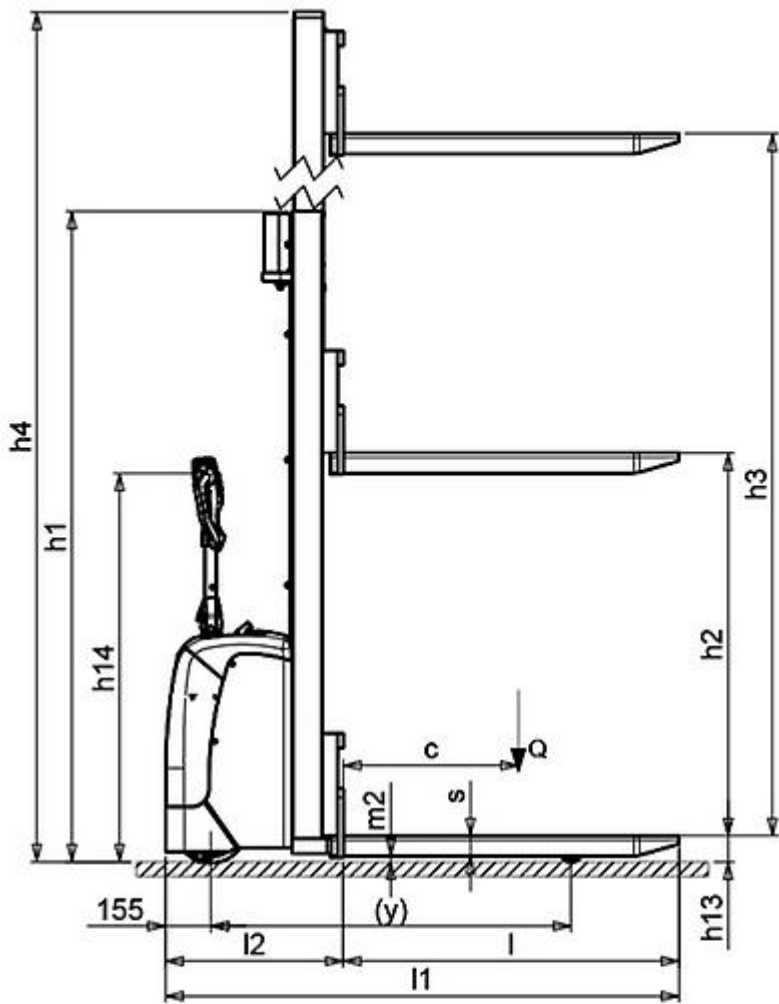

The information is aligned with the Data file at the time of download. Printed on 24/02/2020 (ID 10078)

©2019 | PR INDUSTRIAL s.r.l. | All rights reserved | Image shown may not reflect actual package. Specifications subject to change without notice

